

FSG-FAC

SUCTION FILTERS



MATERIALS

Lid: polyamide
Housing: aluminium alloy
Seals: NBR Nitrile

PRESSURE

Collapse, differential for filter element (ISO 2941): 1 MPa (1 bar)

WORKING TEMPERATURE

From -25° to +110° C

COMPATIBILITY (ISO 2943)

Full with fluids: HH-HL-HM-HV-HTG
(according to ISO 6743/4)
For fluids different than the above mentioned,
please contact our Customer Service



HYDRAULIC DIAGRAM

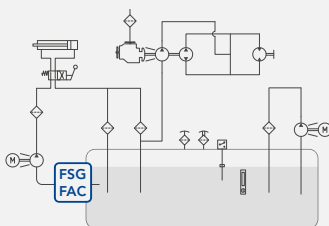

Is this datasheet the latest release? Please check on our website.



FSG

SUCTION FILTERS

ORDERING AND OPTION CHART

F	S	G	COMPLETE FILTER FAMILY			FILTER ELEMENT FAMILY	E	S	G
			SIZE & LENGHT	11	13	SIZE & LENGHT			
		B	PORT TYPE						
			B = BSP thread	B	B				
1	0		PORT SIZE *						
			10 = 1" 1/4	10	10				
		W	BYPASS VALVE						
			W = without bypass	W	W				
			SEALS			SEALS			
			N = NBR Nitrile	N	N				
C	C		FILTER MEDIA			FILTER MEDIA			
			CC = impregnated cellulose 10 µm	CC	CC				
			CLOGGING INDICATOR						
			01 = 1/8" port, plugged	01	01				
			10 = vacuum gauge, rear connection	10	10				
			91 = SPDT, vacuum switch	91	91				
		W	ACCESSORIES						
			W = without	W	W				
		X	ACCESSORIES						
			X = without	X	X				

SPARE PARTS ELEMENTS

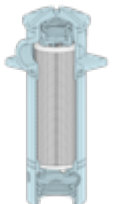
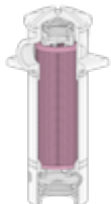
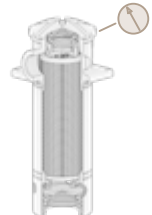
FILTER HOUSING										FILTER ELEMENT					CLOGGING INDICATOR				
																			
B	S	G				0	4												



FAC

SUCTION FILTERS

ORDERING AND OPTION CHART

F	A	C	COMPLETE FILTER FAMILY			FILTER ELEMENT FAMILY	C	A	C
			SIZE & LENGHT	110	130	SIZE & LENGHT			
		C	D FILTER MEDIA			FILTER MEDIA			
			CD = impregnated cellulose 10 µm	CD	CD				
		1	SEALS			SEALS			
			1= NBR Nitrile	1	1				
		S	BYPASS VALVE						
			S = without bypass	S	S				
		B	PORT TYPE						
			B = BSP thread	B	B				
		6	PORT SIZE						
			6 = 1" 1/4	6	6				
			CLOGGING INDICATOR						
			01 = 1/8" port, plugged	01	01				
			10 = vacuum gauge, rear connection	10	10				
			91 = SPDT, vacuum switch	91	91				
		S	ACCESSORIES						
			S = without	S	S				
		X	ACCESSORIES						
			X= without	X	X				

NOTES

* Port size B08 (1") on request, please check availability with our Customer Service

FSG-FAC

SUCTION FILTERS



INSTALLATION DRAWING

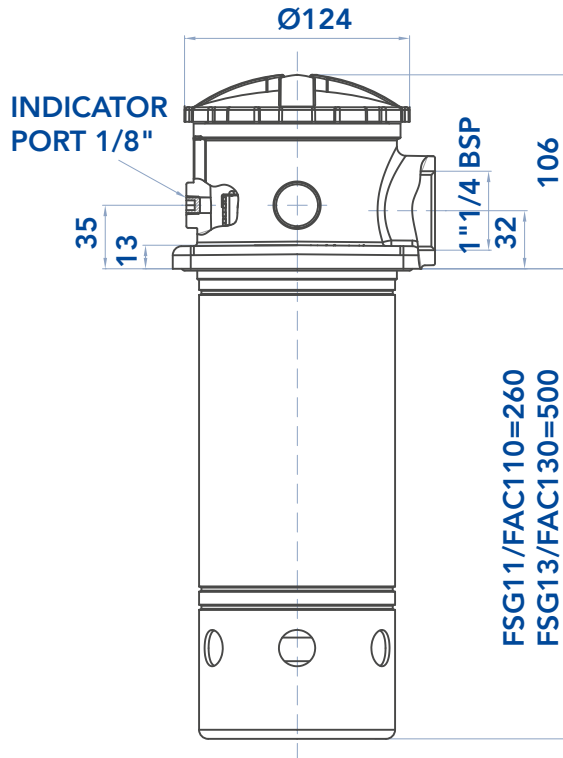

FILTER WEIGHT

	Kg
FSG11 FAC110	2,8
FSG13 FAC130	3,2

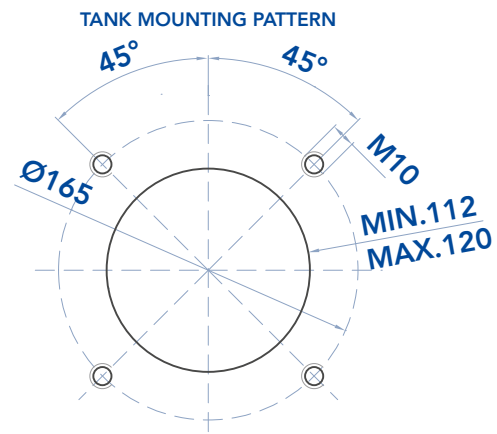
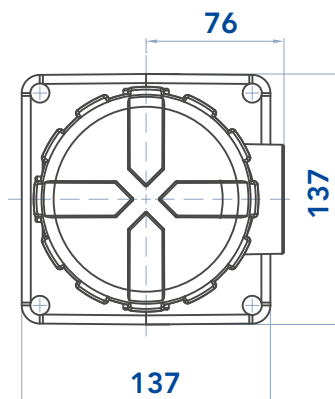

MAINTENANCE

The best time to change your filter element is just before it reaches its maximum dirt-holding capacity. For this reason, we recommend to monitor the pressure of the hydraulic oil flowing through the filter with a clogging indicator. When it is time to change the filter element, switch off the system before opening the filter housing. Unscrew the cover of the filter head and remove the dirty filter element. Replace it with an

original UFI element, verifying the part number on the filter label or on the catalogue. Check the gaskets conditions and replace if necessary. Insert the clean element, handling with care and cleanliness. Screw the cover on the filter head.

We recommend the stocking of a spare UFI filter element for timely replacement when required.

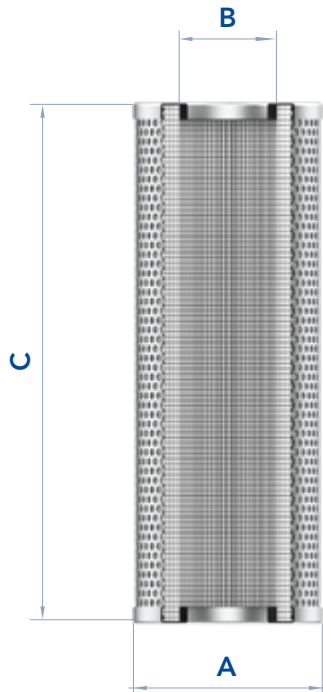

FILTER ELEMENT

	A	B	C	AREA (cm ²)
				Media C
ESG11 CAC110	83	50	230	5.000
ESG13 CAC130	83	50	472	9.300

The used filter elements cannot be cleaned and are classified as “Dangerous waste material”. They must be disposed according to local laws by authorized Companies.

Verify that the Company you choose has the expertise and authorization to dispose this type of waste material.

PRESSURE DROP CURVES (ΔP)

The Pressure Drop (Δp) must be lower than 3 kPa (0,03 bar).

COMPLETE FILTER PRESSURE DROP
(mainly depending on the port size)

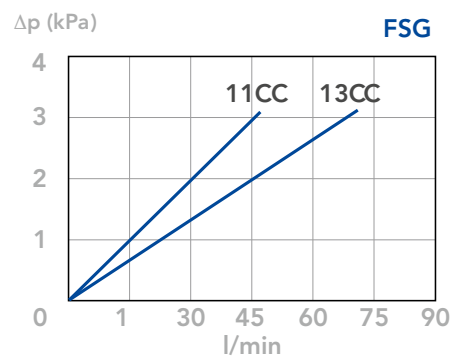

N.B.

All the curves have been obtained with mineral oil having a kinematic viscosity 30 cSt and specific gravity 0,86 kg/dm³; for fluids with different features, please consider the factors described in the first part of this catalogue. All the curves

are obtained from test done at the UFI HYDRAULIC DIVISION Laboratory, according to the specification ISO 3968. In case of discrepancy, please check the contamination level, viscosity and features of the fluid in use.